

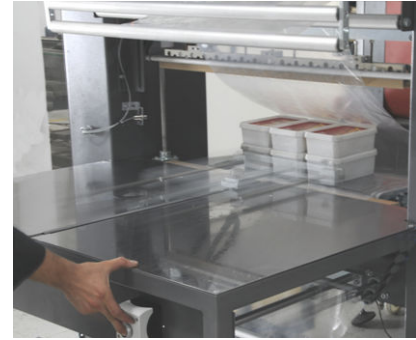

Ambalaj ve Endüstri Mamüleri San.Tic.A.Ş.

MULTIMAC-P & PE-P Semi Automatic Sleeve Wrappers:



Models	Dimensions a x b x c x d x e x g x h (mm)	Seal bar Length	Air supply (per cycle)	Max.film width(mm)	Power supply 400V, 3ph	Consumption (Max/Avg)	Capacity	Weight Net/ Crated
Multimac 60P Kodu:Y12 003 0064	3350x600x1130x960x1850 x960x670x1400mm 132x24x45x38x73x38x26x55"	600mm 23,5"	6 Bar 10dm ³ 608in ³	600mm 23,5"	44 Amper	13,2 / 7,5 kW	6-7 packs/ min	460/520kg 1014/1146 lb
Multimac 80P Kodu:Y12 003 0070	3350x600x1330x960x1850x1160x670x 1400mm 132x24x52x38x73x46x26x55"	800mm 31,5"		800mm 31,5"	46 Amper	17,2 / 8,5 kW		545/628kg 1201/1384lb
PE80-P Code :Y12 098 0212	1485x1085x1485x950x1070x1840 58x43x58x37x42x72"	800mm 31,5"		900mm 35,4"	6 Amper	2,2 / 1,2kW		196/285kg
PE120-P Code :Y12 098 0312	1485x1485x1885x950x1470x1840 58x58x74x37x58x72"	1200mm 47,2"		1300mm 51,8"	8 Amper	3,0 / 1,5kW		235/375kg
PE150-P Code :Y12 098 ****	1485x1785x2185x950x1770x1840 58x70x86x37x70x72"	1500mm 59,5"		1600mm 63"	9 Amper	3,5 / 1,8kW		286/465kg
Color : Metallic dark gray (RAL code : custom color)								
Warranty: One year on non-wearable parts								

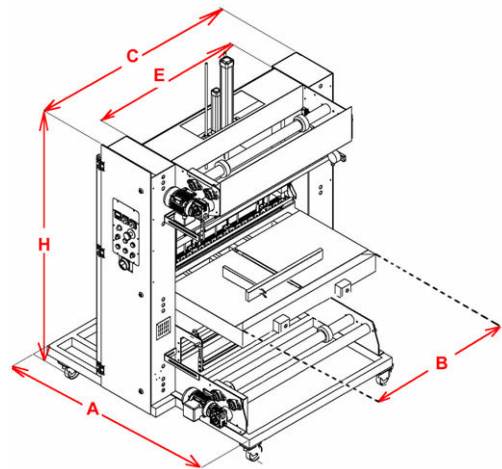
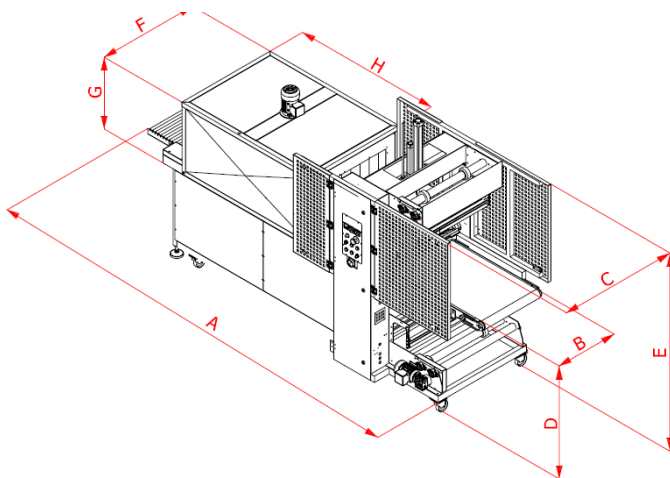

Features:

- Two single wound films are placed on to the upper and lower side film carriage rollers
- Top and bottom motorized film drive and relevant film advance balancer attachments
- Pneumatic pusher with side guides for package infeed
- Max seal bar height: 400mm
- Optional discharge belt until heat tunnel
- Constantly heated sealing bar to give two seals with a center cut fitted with a cartridge heater
- Digital temperature controller to give consistency of seal with a thermocouple control
- Pneumatic cylinder and double heavy duty linear bearings for accurate motion
- Bottom jaw consists of a soft rubber sealing pad covered by easy to replace Teflon tape
- PLC programmed software for customized inquiries and flexibility
- Detection sensor against package or hand entrapment
- Optional holder to keep the package steady during sealing by soft vertical cylinder
- Max. height adjustment for the jaw
- Smooth product transfer through the tunnel conveyor.
- Speed controller for conveyor and heat adjustment for powerful shrinkage at PE films
- Secondary and emergency heat controller for safety regulation
- Air flow control flaps with handle for shrink tunnel
- Post cooling switch to cool down to 70°C before switch off
- Silicon coated tunnel conveyor bars for perfect heat insulation
- Two layer design heating room to minimize the energy losses
- Together with standard casters for easy moving
- Optional wire belt or Teflon mesh belt can be applied upon request
- ISO 9001 quality standard with the relevant norm's confirmations, CE marking,
- Manufacturer's guarantee for spare part stock, one year warranty on non-wearable parts
- ISO 9001 quality standard with the relevant norm's confirmations, CE marking
- Manufacturer's guarantee for spare part stock and after sales support.
- One year warranty on non-wearable parts

